

SE Performance

1070cc Kits

Assembly instructions



SE 1070ccm Torque Kit



SE 1070ccm Sport Kit

FAQ

Dual ignition yes or no? The SE 1070cc kits can be run with single ignition without any problems. However, converting to dual ignition offers the possibility of increasing compression and squish (area between piston crown and combustion chamber at TDC). Both lead to an increase in the medium pressure and thus to more torque and more power.

If the engine is to be operated with single ignition, we recommend setting the ignition timing to the maximum range. otherwise in some cases ignition rings may occur. The necessary stops are included in the kit. For more information and a description of the installation, please refer to the rear part of these installation instructions.

Does the combustion chamber have to be adapted? The SE 1070cc kit can be operated with the original R80 or R100 combustion chamber without any problems. If you want to make it perfect, we recommend adapting the combustion chambers to the larger bore. We offer this service for 75 € per combustion chamber.

We offer two different 1070cc kits. One with short pistons and the necessary long H-connecting rods, the other for use with the original connecting rods. Both kits are identical in design. Both are high-strength forged pistons in "double cross" design. The piston dome is identical, so the compression height and the size of the valve pockets are the same for both kits.

What is the difference? The Power Kit with connecting rod is more suitable for the sportsman. It revs up more spontaneously and freely, but this also means that the throttle response and the stoic good nature of the 2-valve engine becomes somewhat more hectic. For drivers who like this, the sport kit is the right choice. For performance above 85 hp in conjunction with increased revs, it is a must. The Torque Kit retains the good-natured character of the BMW 2V Boxer, but makes it significantly more powerful and, of course, more powerful. The best choice for all power levels up to 85 hp.

Sport Evolution Franzen GmbH

Dachspfad 17
D-56566 Neuwied
Tel.: +49 (0) 2622/92272-0
info@sport-evolution.de

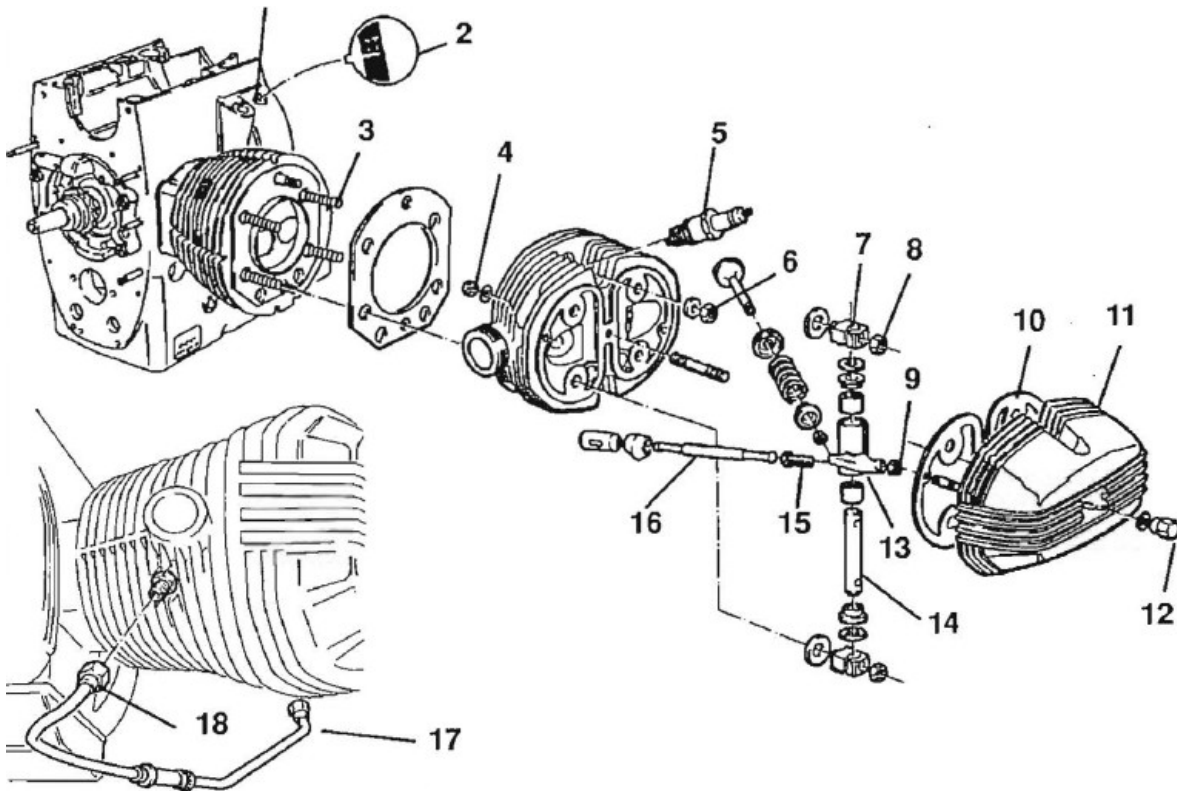

Dismantle cylinder heads

- Remove the cylinder head cover (11) after loosening the cap nut (12) and the 2 fastening nuts (4).
- Remove cylinder head cover gasket (10).
- Remove the spark plug (5).
- Set the piston to compression-OT by turning the clutch flange or, with the engine installed, set 5th gear and adjust TDC by turning the rear wheel.
- Loosen the union nut (18) of the SLS system and remove the pipe (17).

NOTE:

The compression TDC is reached when the TDC mark (2) appears in the inspection hole on the engine housing on the left (1) and the intake and exhaust valves of the corresponding cylinder are closed (play can be felt on the rocker arm).

- Loosen the lock nuts (9) on the adjusting screws (15).
- Remove the rocker arm (13) after loosening the 4 collar nuts (8) together with the clamping blocks (7) and rocker arm axles (14).
- Remove the push rods (16).
- Loosen cylinder head nuts (6).
- Loosen the cylinder head from the cylinder by lightly bouncing it with a plastic hammer.
- Pull the cylinder head off the tie rod screws (3).

NOTE:

After dismantling the cylinder heads, we recommend disassembling them and checking the valve guides, valve seat inserts and valves for wear. If you do not have the confidence to inspect the heads, you are welcome to send them to us for inspection and, if necessary, overhaul.

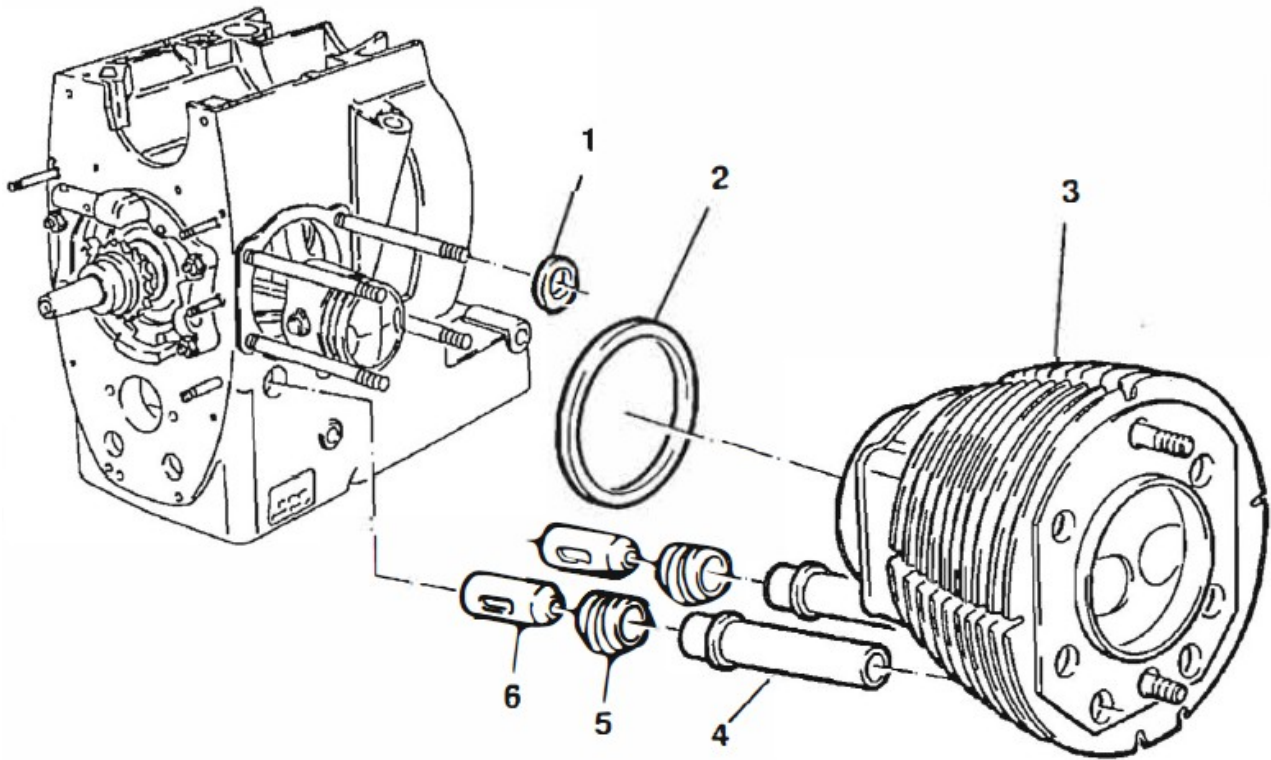

REMOVE CYLINDER

- Loosen cylinder (3) with impact blows (plastic hammer).
- Pull the cylinder off the housing.
- Pull the tappet (6) out of the guides and check it.
- Remove sealing rubbers (5) from the pushrod tubes (4).
- Remove the O-ring (2) from the cylinder base.
- Remove the O-rings (1) from the upper stud bolts.

NOTE:

The O-rings described must be replaced after each removal. The large O-ring at the base of the cylinder is not used on all models/model years.

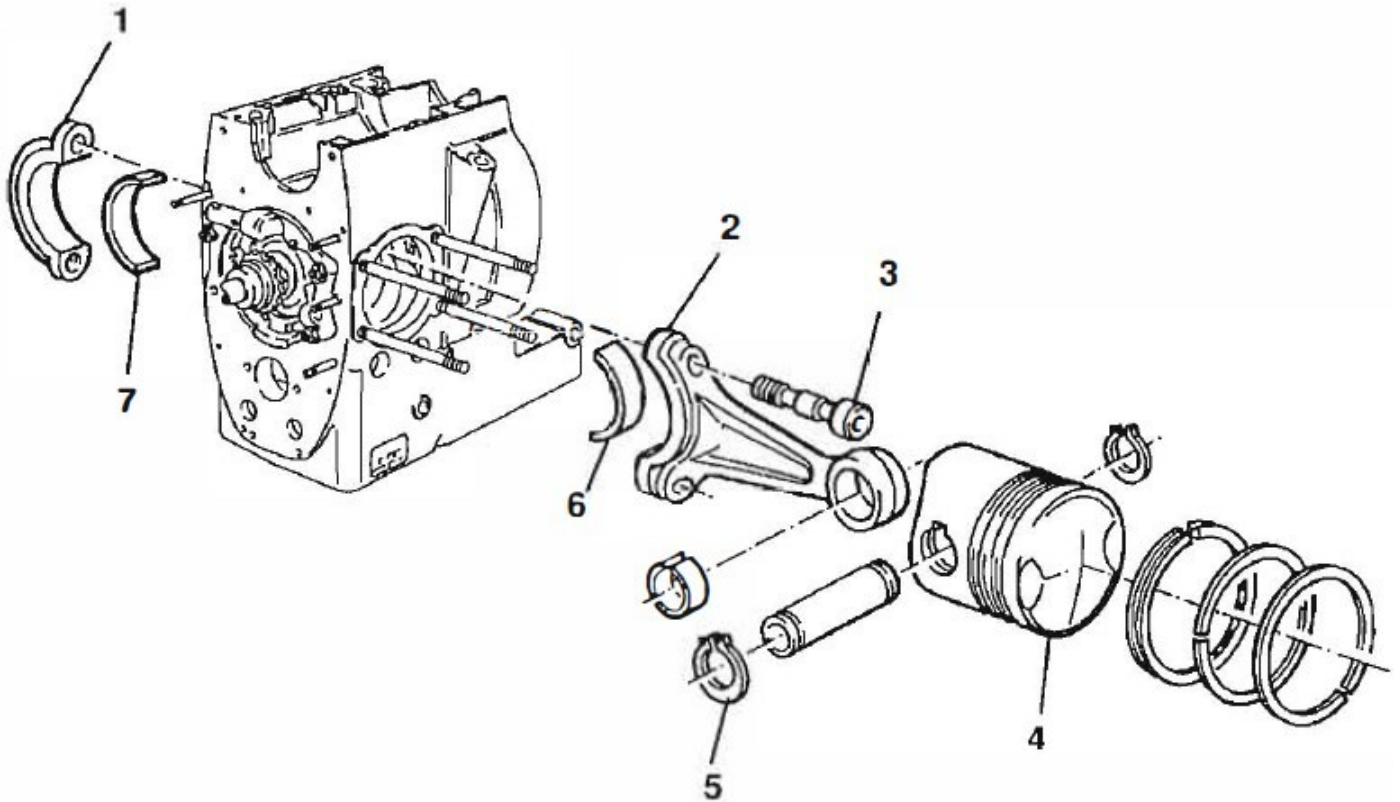

Remove connecting rod

- Remove the circlip (5) on the left/right piston pin with circlip pliers.
- Push the piston pin out of the connecting rod and piston by hand.
- Remove piston (4)
- Loosen the connecting rod screws (3) with a 10 mm hexagon socket (XZN).
- Remove connecting rod (2) and connecting rod bearing cover (1) together with bearing shells (6, 7).

NOTE:

Disassembly of the connecting rods is not necessary when using the SE 1070cc Torque Kit (piston kit for use with original connecting rods).

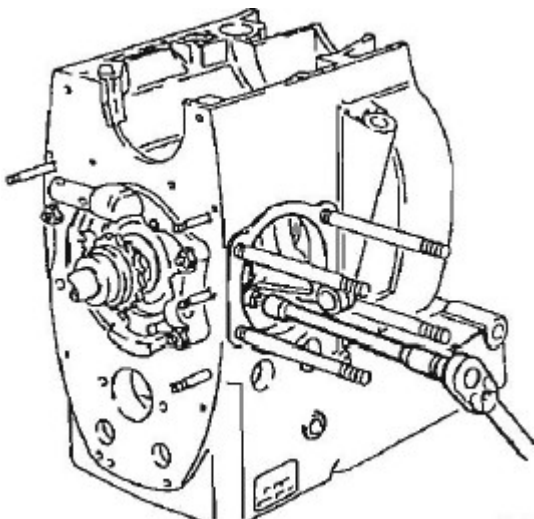

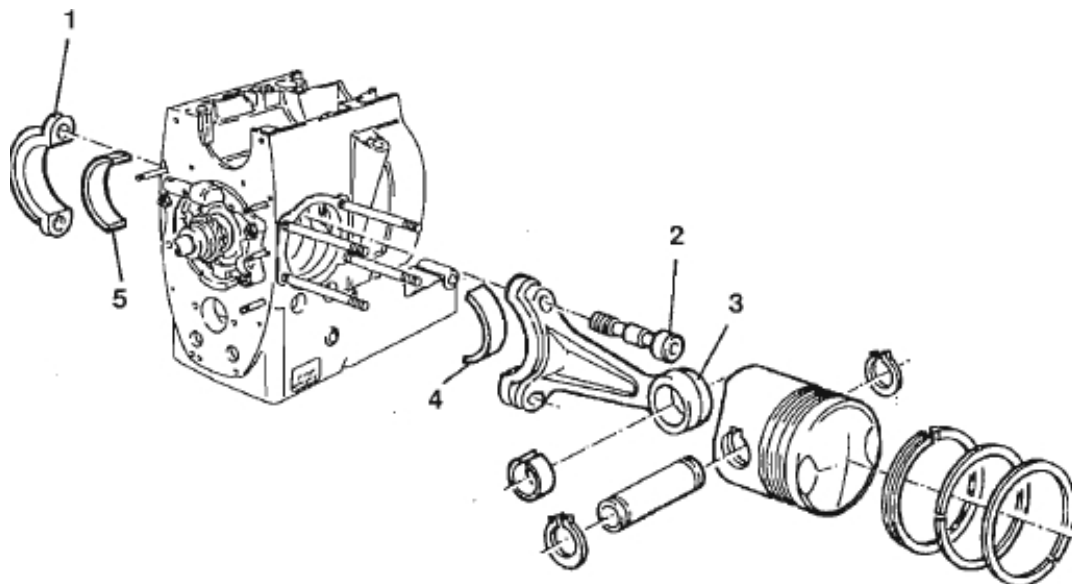

Connecting rod and Install piston

- The installation is carried out in TDC position of the crankshaft.
- Clean the connecting rod bearing bore.
- Press bearing shells (4, 5) into connecting rod bearing base bore.
- Hollow out the connecting rod bearings and the connecting rod journal of the crankshaft well.
- Place connecting rod (3) and connecting rod bearing cap (1) on crankshaft.
- Fit both connecting rods so that the fixing pins of the connecting rod bearings are on the generator side.

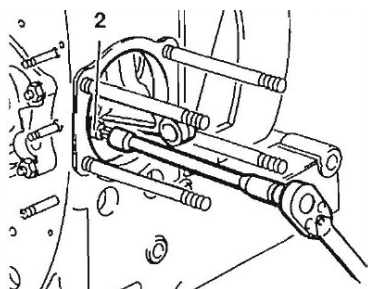

- Using a 12-sided socket, screw in the connecting rod screws (2) and tighten with the prescribed tightening torque and/or angle of rotation.
- Apply molybdenum grease to the screw threads and the contact surface of the screw head.

Connecting rod original (SE 1070 Torque Kit)

- | | |
|---------|------|
| 1. Step | 20Nm |
| 2. Step | 40° |
| 3. Step | 5° |

Inside 12-sided socket 10mm (XZN)

SE H connecting rod (SE 1070 Sport Kit)

- | | |
|---------|--|
| 1. Step | 20Nm |
| 2. Step | 36Nm |
| 3. | StepScrew the connecting rods again External 12-sided nut "3/8 |

This procedure must be repeated 3 times (do not loosen the connecting rod again during the third repetition).

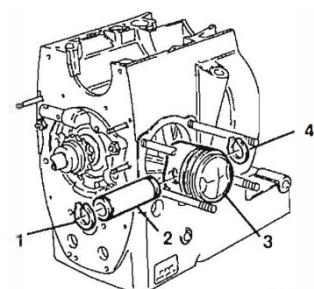

- Place piston (3) on connecting rod and insert piston pin (2).
- Insert circlips (1,4) into the ring groove on the piston pin.

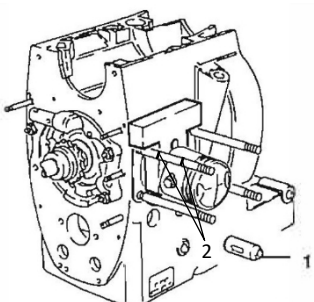

- The cylinder base and cylinder sealing surfaces on the engine housing must be free of grease.
- Insert the plunger (1) into the guides.
- When inserting the cylinder into the motor housing, make sure that the O-rings are not crushed.
- Make sure that the piston ring joints are twisted 120° against each other before fitting the cylinder.
- Place two of the enclosed O-rings (2) on each of the two lower stud bolts. at a distance of 40mm from the motor housing. These O-rings (8.00mm x 1.50mm) only serve as a centring aid and have no sealing function.

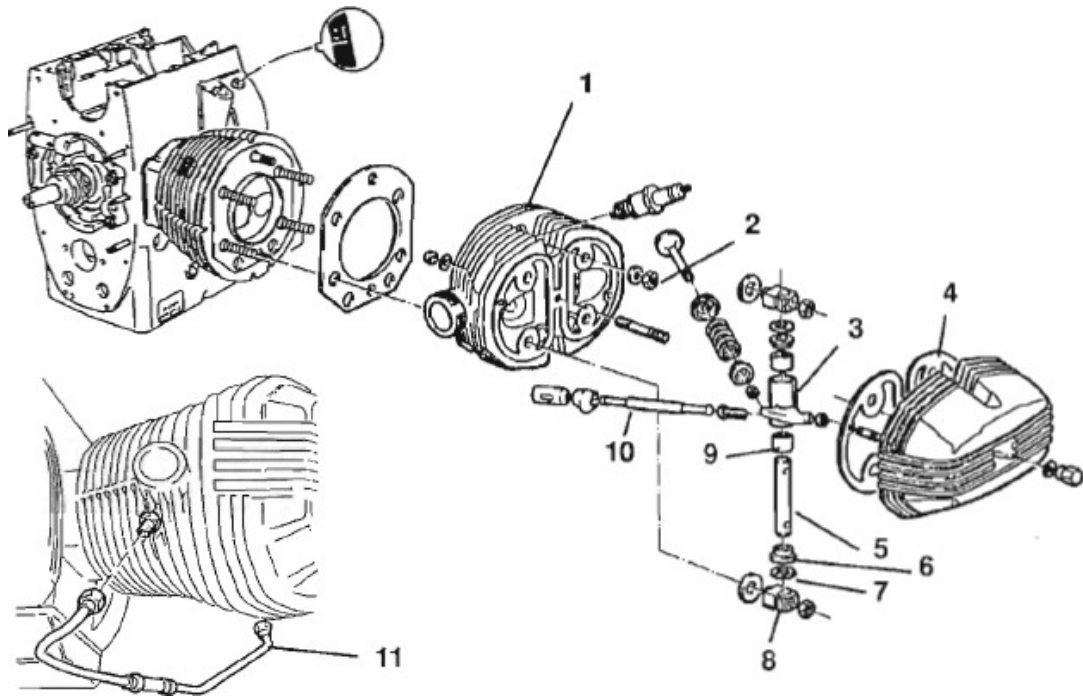

- Fit the cylinder (1) onto the 4 tie rod screws.
- Hold piston rings together with piston ring tensiometer.
- Slide cylinder over piston and insert into engine housing.

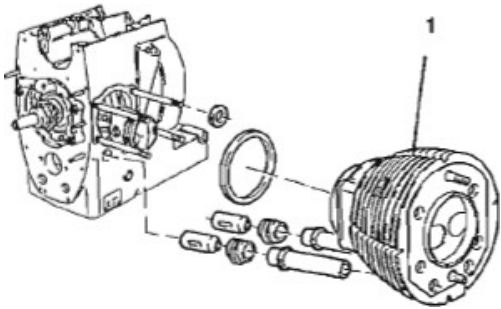

Tip:

It is easier to insert the piston into the cylinder first and then place the cylinder/piston unit on the connecting rod.

Fitting the cylinder head

- Fit the cylinder head gasket (4).
- Fit the cylinder head (1) onto the 4 tie rod screws.
- Screw the cylinder head to the cylinder with 2 nuts (2).
- Insert the push rods (10).
- Rocker arm (3) complete with rocker arm axle (5), Pertinax (6), shims (7), bearings (9) and clamping brackets onto the tie-rod bolts and screw them tight. (8)

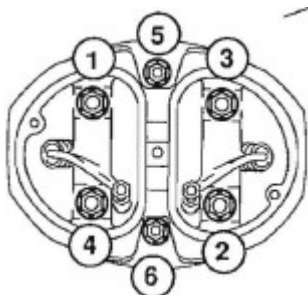

- Tighten the collar nuts (6) and the fastening nuts (2) in 3 steps according to the tightening diagram/sequence with the prescribed tightening torque.

1st step 15Nm - 2nd step 25Nm - 3rd step 35Nm

- Adjust valve clearance E=0.10mm, A=0.20mm

NOTE:

The cylinder head must be retightened after 1,000 km with 35 Nm. The valve clearance should then be checked.

Limiting ignition timing for contactless ignition systems all 2-valves

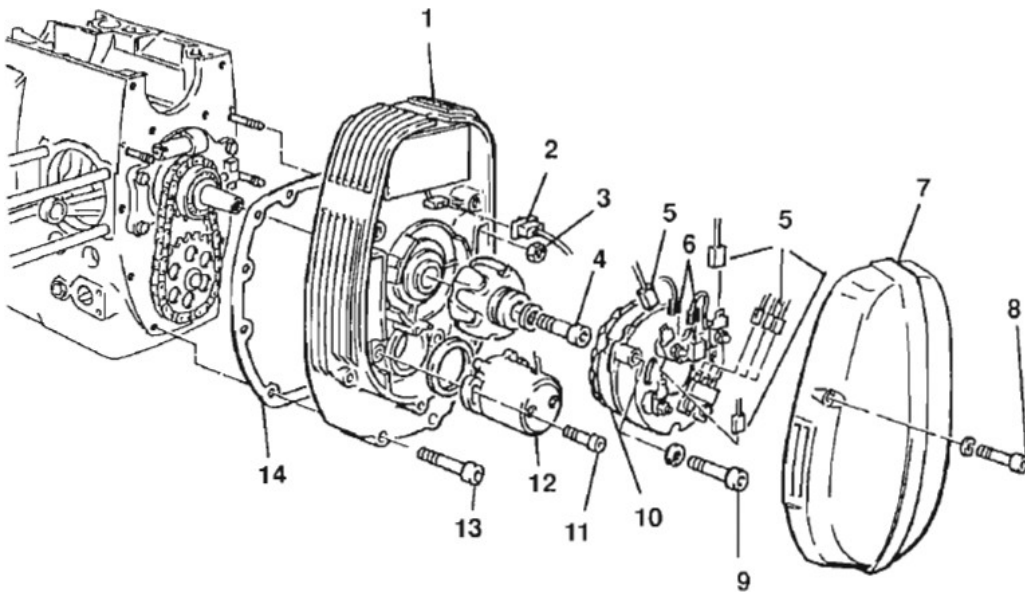

In some cases it may be necessary to limit the maximum pre-ignition. These small stops are inserted on the centrifugal adjuster instead of the red bushes. This reduces the maximum pre-ignition by approx. 5-6 °.

- necessary with high compression with original ignition system
- suitable for all 2V with contactless ignition system
- is placed in the pulse generator socket (12) on the original centrifugal governor
- replaces the original red cans
- Static ignition timing remains the same

Note: We recommend the use of this ignition timing limiter when using a 1070cc kit without dual ignition.

