

👁 Note!

Please note that there can be small differences between your product and the images in these instructions.

👁 Note!

Please note that during storage and transport, especially at high ambient temperature, some of the oil and grease used for assembly may leak and stain the packaging. This will not cause damage to the product, wipe off the excessive oil or grease with a cloth.

Kit Contents

Description	Part No	Pcs
Front fork	FGRT218	1 set
Fender bracket	21665-02	2
Screw MC6S 5x10	01046-38	4
Sticker set Öhlins		1
Owner's manual	07282-07	1

👁 Note!

Before you install this product, check the kit contents. If anything is missing, please contact an Öhlins dealer.

⚠ Warning!

Before you install this product, read the Öhlins Owner's manual. This product is an important part of the vehicle and the vehicle stability.

Front Fork for BMW R nineT

FGRT 218

Mounting Instructions



MOUNTING INSTRUCTIONS

⚠ Warning!

We strongly recommend to let an Öhlins dealer install this product.

⚠ Warning!

If you work with a lifted vehicle, make sure that it is safely supported to prevent it from tipping over.

👁 Note!

When you work with this product, see the vehicle service manual for vehicle specific procedures and important data.

👁 Note!

Before you install this product clean the vehicle.

1

Put the motorcycle on a work stand so that the front wheel barely touches the ground.

2

Remove the brake caliper, front wheel and front fender.

3

Remove the ABS-sensor from the standard front fork.

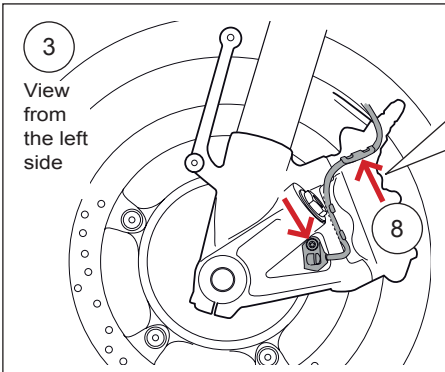

4

Loosen screws on the upper and lower triple clamp.

5

Remove the fork legs from the triple clamps

6

Install the fork legs into the triple clamps at the recommended position in the set-up data (Fork leg position). Turn the handle bars fully from side to side to make sure that nothing restricts the movement, and that the throttle cable and wire harness runs in smooth bends.

⚠ Warning!

The surface of the outer machining must be 90° from the vehicle direction.

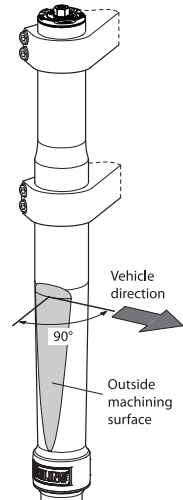
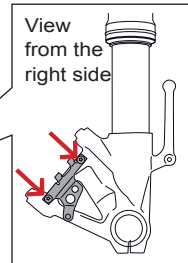

7

Tighten the triple clamp screws to torque according to the vehicle service manual.

8

Install the ABS-sensor on the Öhlins front fork. Use the standard bracket on the brake calliper to clamp the cable.

👉 Caution!

Make sure that the ABS sensor cable runs in soft bends so that it does not get damaged.

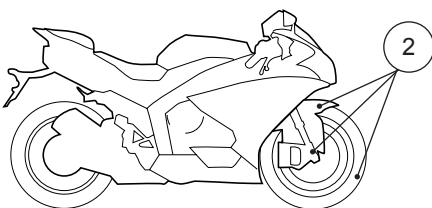

MOUNTING INSTRUCTIONS

9

Install the supplied fender brackets to the fork legs according to figure. Apply Loctite 243 or similar to the screws (01046-38).

Tighten to 4 Nm.

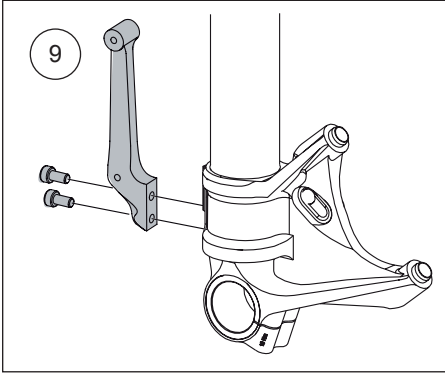

10

Reinstall the front fender, front wheel and the brake calipers. Do not tighten the front wheel yet.

11

Put the bike on the ground, apply the front brake and compress the front fork distinctly 3-4 times. This will put the legs in an exact parallel position.

12

Tighten the front wheel. Consult your vehicle service manual for correct tightening torques.

ADJUSTMENTS

⚠ Warning!

Before riding, always make sure that the basic settings made by Öhlins are according to recommended Set-up Data. Read the Öhlins Owner's Manual before you make any adjustments. Contact an Öhlins dealer if you have any questions about setting up the front fork.

👁 Note!

In storage or transport the oil in the front fork can be displaced and therefore temporarily loses some of its damping performance.

13

Close the rebound and compression adjusters.

14

Repeatedly compress the front fork as much as possible to bleed the air out. Ensure there is damping on the full stroke.

15

Set the rebound and compression adjusters according to recommended setup.

16

Read more in the Öhlins Owner's manual.

👁 Note!

Lower the vehicle so that the suspension is slightly compressed before you tighten the screws.

👋 Caution!

Make sure that you tighten all screws to the correct torque and that nothing fouls or restricts movement of the shock absorber/front fork/steering damper when the suspension is fully compressed or extended.

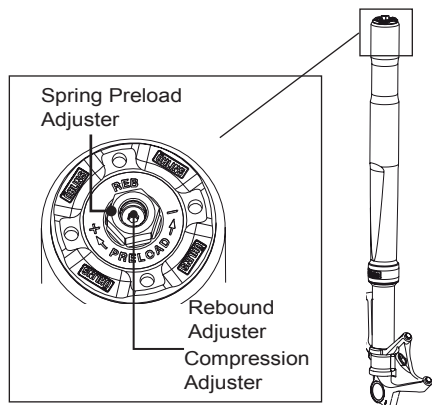

SETUP DATA

Recommended setup		
Rebound	18	clicks
Compression	14	clicks
Spring preload	9	mm
Spring rate	9	N/mm
Oil level	130	mm
Öhlins front fork fluid	Part no	01309-01
Fork leg position	Standard pos.	

Spring part no.		Rate N/mm
04744-10	Optional	10,0
04744-90	Standard	9,0
04744-95	Optional	9,5
04744-05	Optional	10,5
04744-11	Optional	11,0

Air spring for one leg

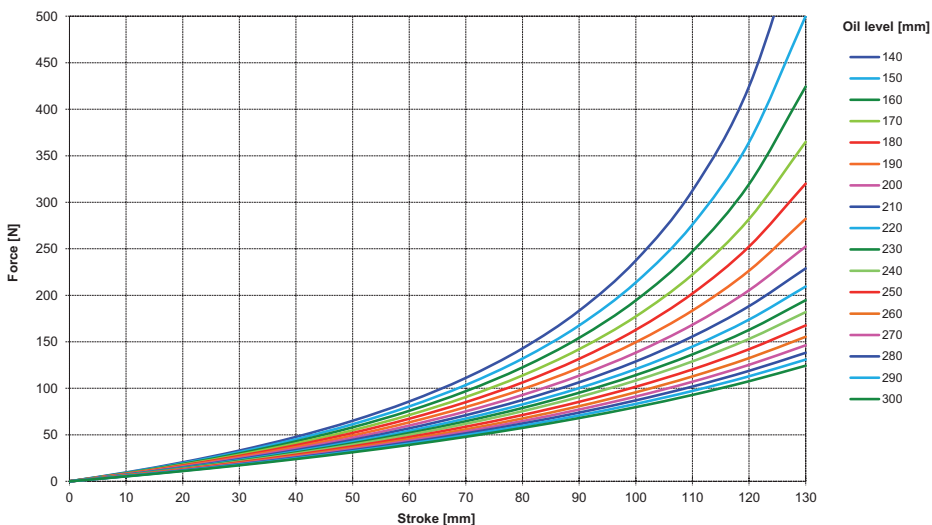

Öhlins products are subject to continuous improvement and development, therefore, although these instructions include the most up-to-date information available at the time of printing, minor updates may occur.

To find the latest information contact an Öhlins distributor. Please contact Öhlins if you have any questions regarding the contents in this document.

Part no. MI_FGRT218_1
Issued 2017-01-01

© Öhlins Racing AB. All rights reserved. Any reprinting or unauthorized use without the written permission of Öhlins Racing AB is prohibited.

Öhlins Racing AB
Box 722
S-194 27 Upplands Väsby, Sweden
Phone +46 8 590 025 00
fax +46 8 590 025 80



www.ohlins.com